

F 1 Transformador de 3 a 5 Amp. y 15 + 15 voltios en el secundario

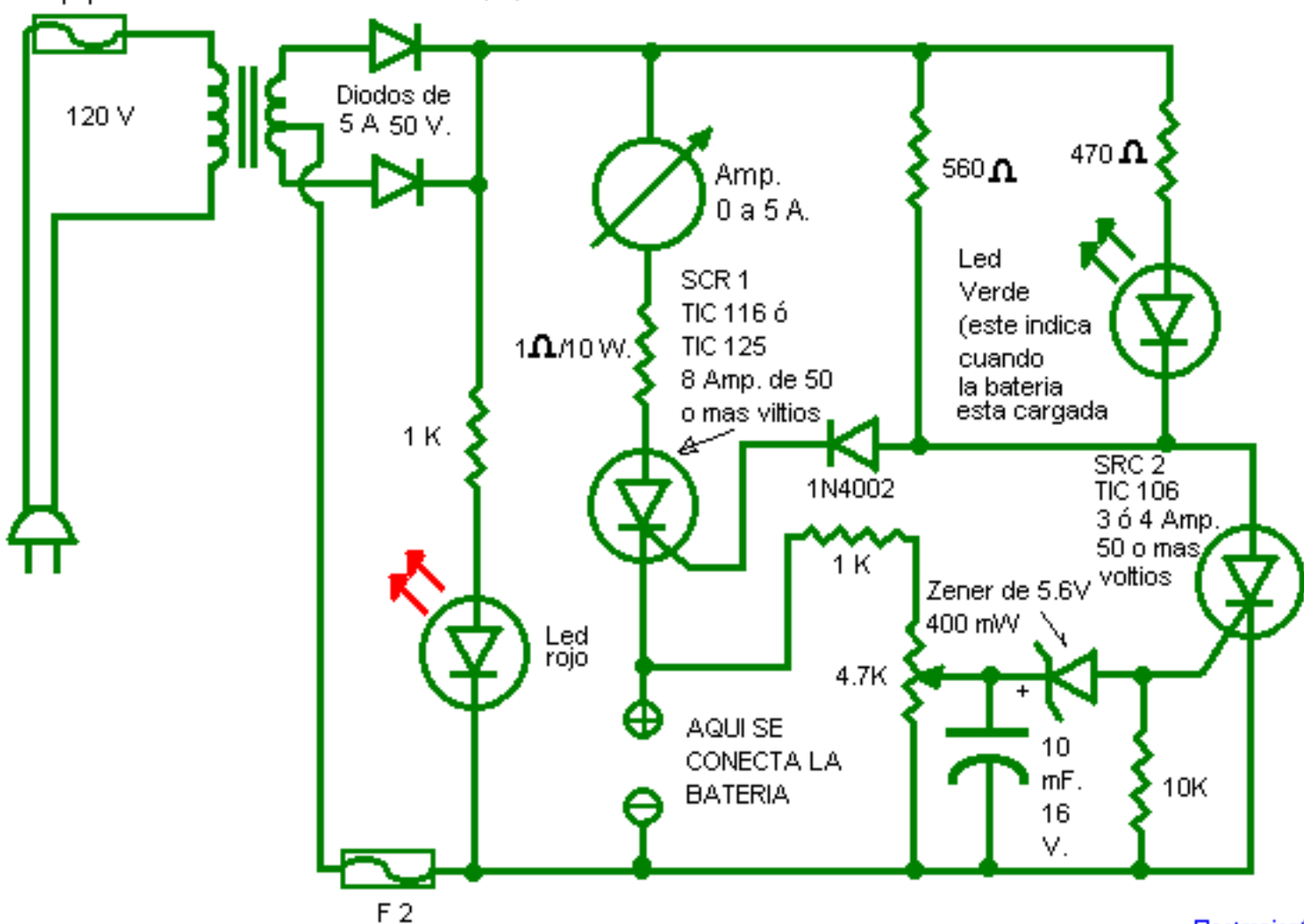

TAB. DE CIRC. IMP. DEL CARGADOR AUTOMÁTICO DE BAT HM

