

RESISTORES: 1/4 DE VATIO
Ver diagrama del ohmetro digital

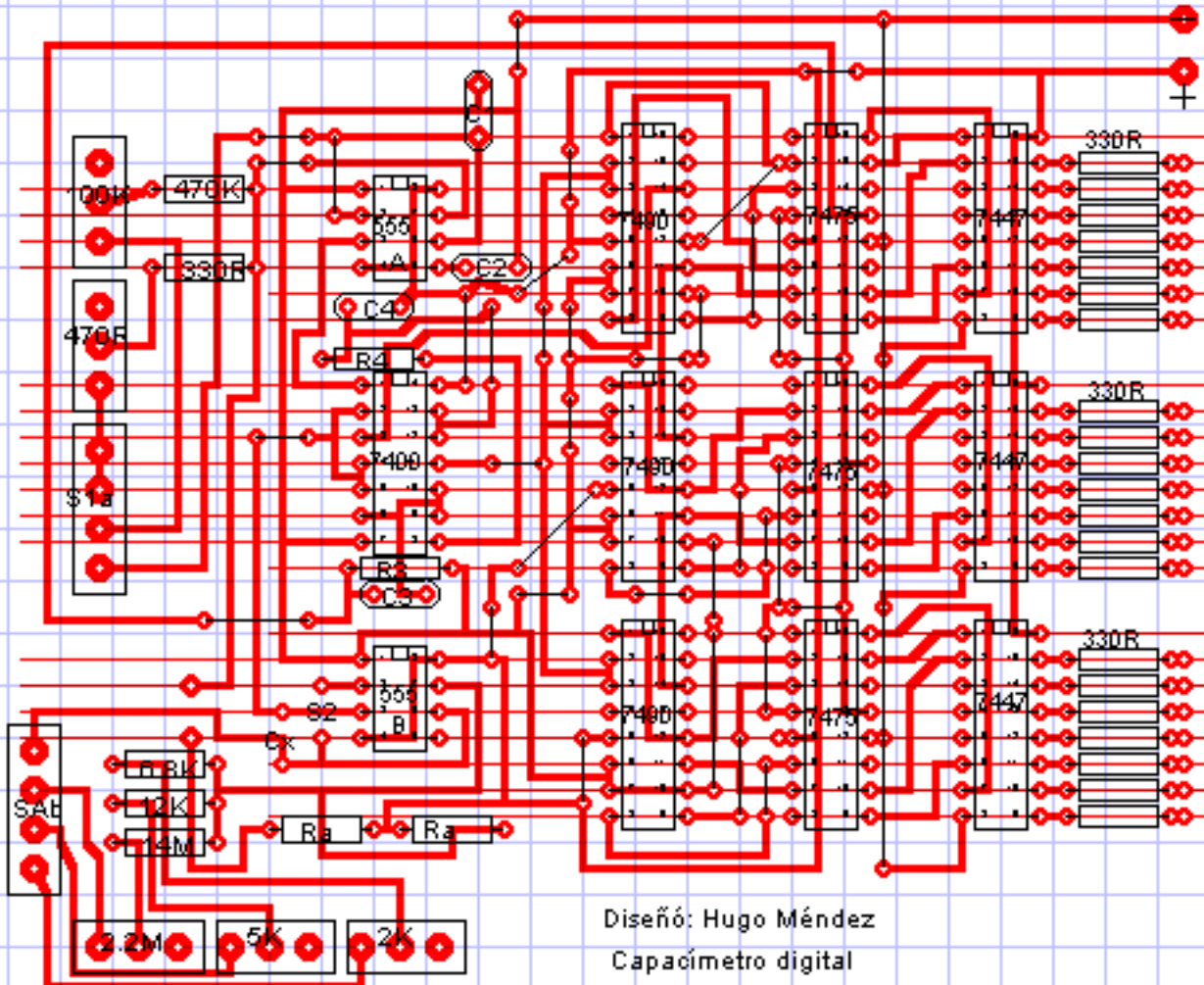

Diseño: Hugo Méndez
 Capacímetro digital

