

## CONTROL POR TOQUE

HM

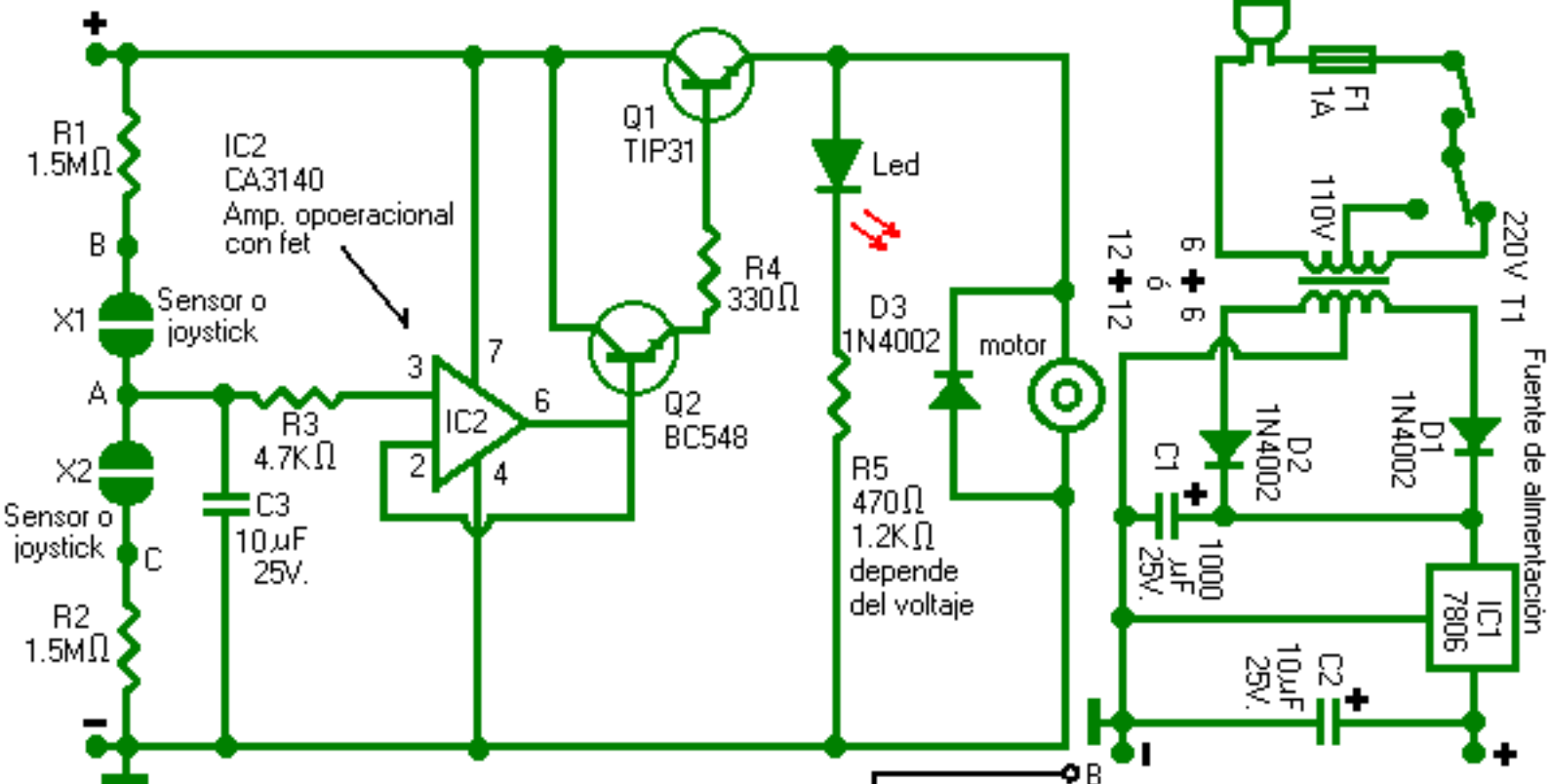

NOTA: Los sensores pueden ser plaquitas de metal cercanas para que al tocarlas con el dedo se toquen simultáneamente.

Si se usa joystick, conectar según la figura

